

OPERATING INSTRUCTIONS AND PART MANUAL

MODEL: 9317 Oil Extractor

9 LITERS MANUAL FLUID EXTRACTOR



CAREFULLY READ THIS MANUAL BEFORE OPERATING THE UNIT



WARNING: Please read all instructions and warnings carefully before to use

- Do not use the unit with gasoline.
- For security reasons, do not use the unit to extract or store dangerous chemicals, poison, acid, alkaloid, or solvents.
- Do not use the unit to extract, siphon or store petroleum or other highly inflammable liquids.
- Do not throw, drop or mishandle the unit.
- Do not disassemble, tamper with or modify the unit for any other purpose than what it was originally intended for.
- Do not store either the unit or suction tubes near or in areas of high temperatures, direct sunlight, rain or snow.
- The unit must be instantly, drained, washed and cleaned after each use.
- Do not use this unit with fluids at temperatures above 175°Fahrenheit (80°Celsius).

Application:

- Engine Oil
- Brake Fluid
- Power Steering oil
- Gear Oil
- Coolants
- Transmission oil

Features:

- A large 9.0 Liter (2.35gallon) capacity.
- Manual fluid extractor can be used to extract many kinds of non-explosive liquids.
- Completely using hand pump when you without shop air.
- New safety design, when the tank is full of liquid, the vacuum will be shut off automatically.
- One man, fast, clean and easy operating.
- None electric spark, safety for workshop.

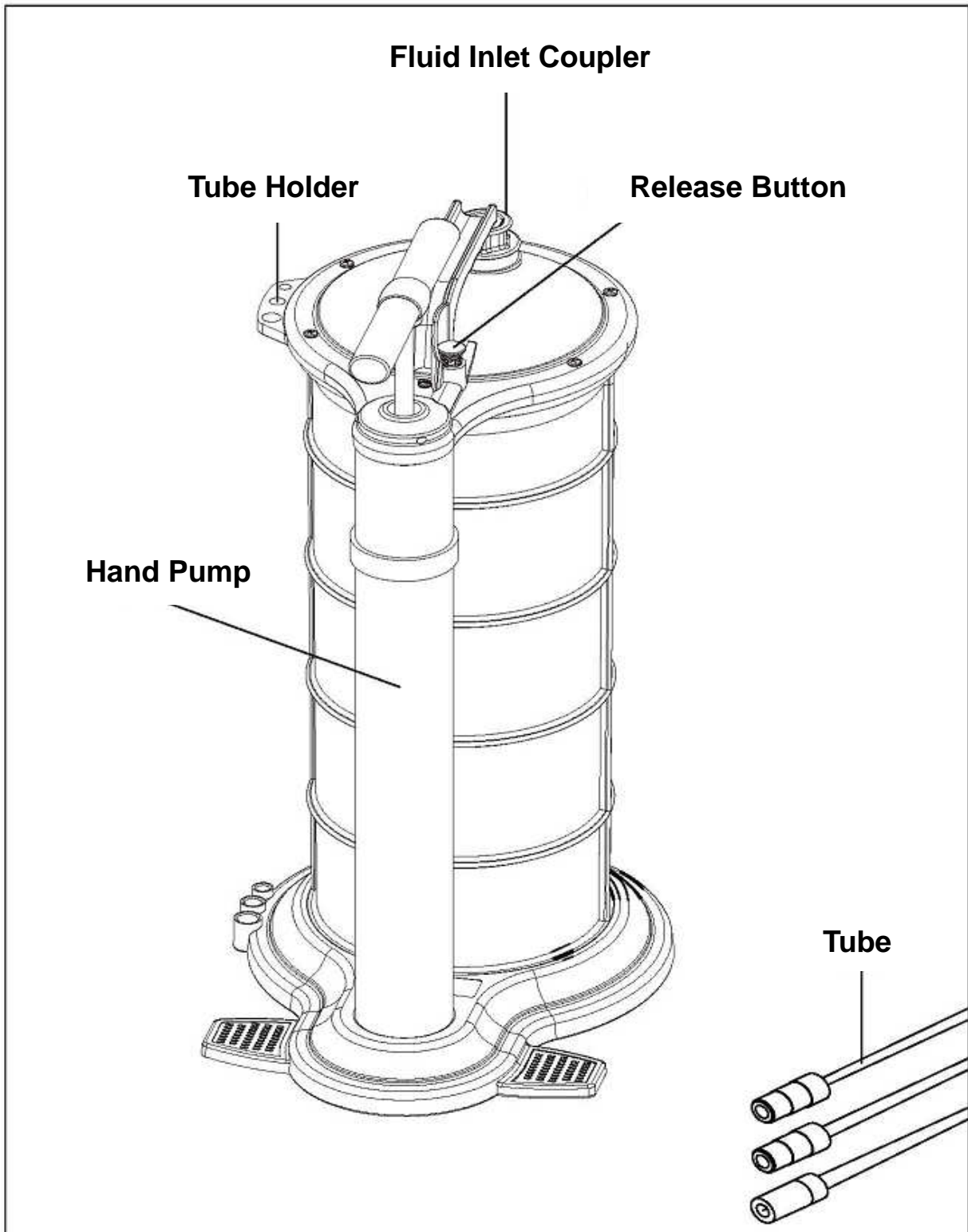

Includes:

- Main Suction Tube: 10mm (OD) x 110 CM
- Extracting Suction Tube: 6mm (OD) x 110 CM
- Extracting Suction Tube: 4mm (OD) x 110 CM
- User Manual

OPERATING INSTRUCTIONS

Notes:

When using the Manual Fluid Extractor unit to extract engine oil, first you need to make sure the vehicle is level, and then run the engine for about 5 minutes to warm the oil and allow any sludge or contamination within the oil to mix.



Operating Steps:

1. Remove the oil dipstick from the engine.



2. Insert the Extracting tube into the dipstick hole until it reaches the bottom of oil pan. connect the Main Suction Tube into the Fluid Inlet Coupler with Main Suction Tube Adapter.

The Main Suction Tube will connect to the Extracting Tube with Extracting Tube Adapter.

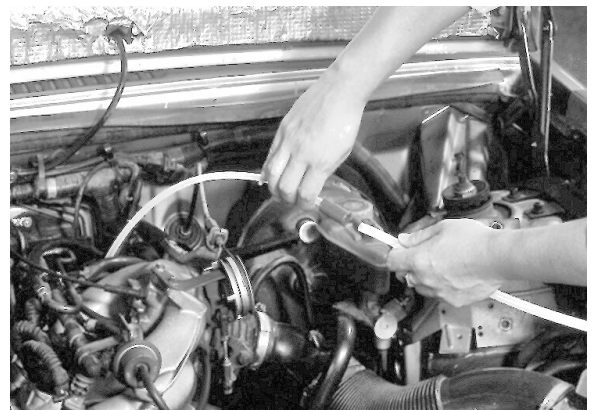

3. Lift the Handle of Hand Pump to the top position and press it to the bottom position repeatedly. The Extractor Unit will start operation.

4. When the fluid inside the extractor tank reaches “Full” position, the Extractor Unit will shut off automatically; the Handle of the Hand Pump will lock. Push the Release Button on the side of the Cover Housing, and then press the Handle of Hand Pump to the bottom position to release Hand Pump from locked position.

5. Disconnect the Main Suction Tube and the Extracting Tube removes them from the dipstick hole. Open the Fluid Inlets Coupler and dispose of the oil or fluid in accordance to the laws and guidelines of your state.

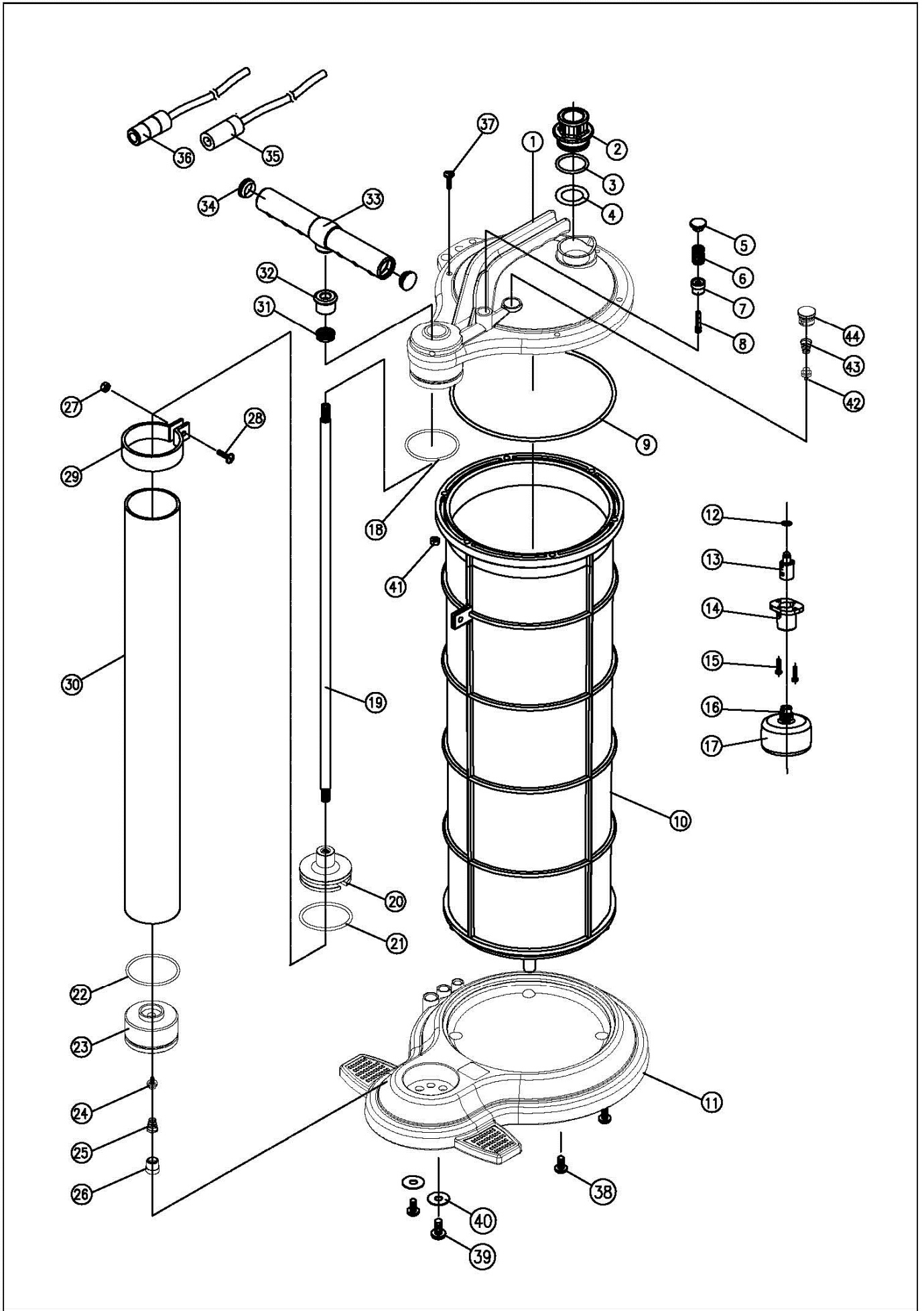

PART LIST

Index	Part No.	Description	Unit
1	M300-01	Cover Housing	1
2	PX90-06	Fluid Inlet Coupler	1
3	PX90-14	O Ring 25.2 X 2.7 mm	1
4		O Ring 20 X 3 mm	1
5	PX90-49	Valve Push Button	1
6	PX90-49-1	Spring	1
7	PX90-49-6	Locking Bushing	1
8	PX90-49-3	Shaft	1
9	PX90-13	ORing 155 X 5 mm	1
10	PX90-02	Reservoir Tank	1
11	M300-02	Base	1
12		O Ring 3 X 2 mm	1
14	PX92-24	Float Fixed Bracket	1
15	PX92-25	Screw M3.5 X 15 mm	2
16	PX92-26	Float Adapter	1
17	PX92-27	Float	1
18	M300-06	O Ring 47 X 3 mm	1
19	PX90-18	Shaft	1
20	M300-04	Piston	1
21	M300-07	O Ring 44 X 5 mm	1
22	M300-06	O Ring 47 X 3 mm	1
23	M300-05	Alum. Tube Base	1
24	PX90-51	Check Valve	1
25	PX90-49-5	Spring	1

Index	Part No.	Description	Unit
26	PX90-49-6	Locking Bushing	1
27	PX90-39	Nut M5	1
28	PX90-38	Screw M5 X 16 mm	1
29	PX90-19	Holder	1
30	M300-03	Alum. Tube	1
31	PX90-28	Oil seal	1
32	PX90-27	Holder	1
33	PX90M-16	Handle	1
34	PX90M-20	Cap	1
35	PX90-30	Main Suction Tube (10 X8) W/ Adapter	1
36	PX90-31	Extracting Tube (6 X 4) W/ Adapter	1
36-1		Extracting Tube (4 X 2) W/ Adapter	1
37	PX90-43	Screw M5 X 20 mm	6
38		Screw M6 X 20 mm	4
39	PX90-36	Screw M8 X 16 mm	2
40		Flat Washer M8	2
41	PX90-39	Nut M5	6
42	PX90-51	Check Valve	1
43	PX90-49-5	Spring	1
44		Cover	1